

## Industrial Ethernet Extender Wolverine DDW-x42 series

- **Compact Industrial Ethernet Extender**
  - Point-to-point, ring or multidrop applications
  - Advanced WeOS functionality
  - Low power consumption
- **Designed for use in industrial applications**
  - Redundant 12/24-48 VDC dual input power supply
  - Highly configurable I/O contact
  - Robust metal DIN rail housing
- **Robust for long service life**
  - Market-leading MTBF (Mean Time Between Failures)
  - -40 to +74°C without moving parts or ventilation holes
  - Industrial, marine and trackside type tested
- **Unique future proof industrial networking solutions**
  - Resilience and high availability solutions
  - Serial legacy support
  - Designed based on IEC 62443 demands



Westermo's Ethernet extender technology based on SHDSL makes it possible to reuse many types of pre-existing copper cables, which can lead to considerable financial savings when installing new or updating existing systems. The SHDSL technology enables long distance connections of Ethernet interface (up to 15 km/9.3 mi) at data rates up to 15.3 Mbit/s on a single twisted pair cable. By using two pairs "bonded", this rate can be doubled up to 30.6 Mbit/s. The built-in switch allows two Ethernet devices to be attached. The DDW-x42 series also supports one serial RS-232 or RS-485 interface.

Only industrial-grade components are used which ensures a long service life and an MTBF (Mean Time Between Failures) of up to 437,000 hours according to the tough military standard MIL-HDBK-217. A wide operating temperature range up to -40 to +74°C (-40 to +165°F) is supported with no moving parts or ventilation holes in the case.

The DDW-x42 series is often used in applications on railways, roads or with utilities where failure could result in significant costs. To ensure reliable operation, the DDW-x42 series has been tested both by Westermo and external test labs to meet the most recognized standards related to EMC, isolation, vibration and shock. All to the highest levels suitable for the tough applications the product is designed for.

The DDW-x42 series is powered by Westermo Operating System, WeOS. WeOS delivers unique security functionality as well as allowing the products to form part of a resilient multimedia ring network using the Westermo FRNT protocol or industry standard STP/RSTP. In addition, it contains amazing serial connectivity capability – from being able to simulate an old AT modem, convert Modbus RTU to TCP or encapsulate serial data into an IP packets. The DDW-x42 series is incredibly flexible and easy to use. A basic point-to-point or multidrop network can be created without the need for any kind of configuration.

# Specifications - DDW-x42 series

## Dimensional drawing

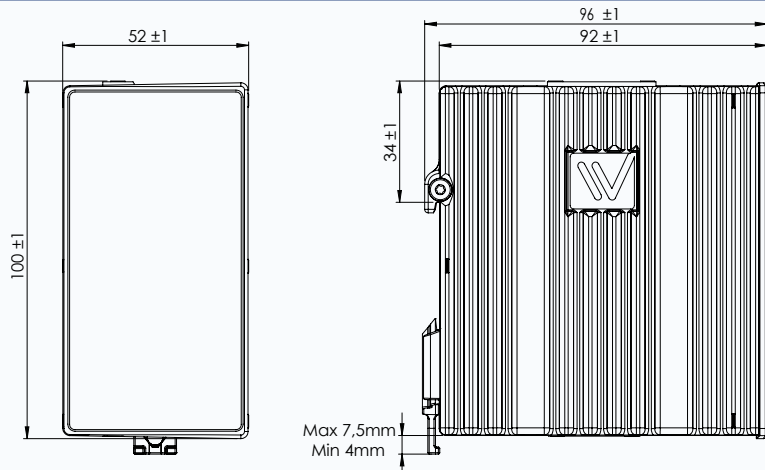

## Housing

Dimensions (W x H x D)	52 x 100 x 101 mm (2.04 x 3.93 x 3.97 inches)
Housing	Full metal
Weight	0.7 kg

## Power parameter

	12 VDC power supply	24 VDC power supply
Rated voltage	12 to 48 VDC	24 to 48 VDC
Operating voltage	9.6 to 60 VDC	19 to 60 VDC
Rated current (without USB load)	475 mA at 12 VDC 245 mA at 24 VDC 124 mA at 48 VDC	245 mA at 24 VDC 124 mA at 48 VDC
Galvanic isolation to all ports	yes	yes

## Environmental

Operating temperature	-40 to +70°C (-40 to +158°F) <sup>a</sup>
Storage and transport temperatures	-50 to +85°C (-58 to +185°F)
Ingress protection	IP40
Humidity (operating)	5-95% relative humidity
Corrosive gases	IEC 60068-2-60
Altitude	2000 m/70 kPa

<sup>a</sup>For DDW-x42-12VDC: -40 to +74°C (-40 to +165°F)

Approvals	
EMC	EN 61000-6-1, Immunity residential environments
	EN 61000-6-2, Immunity industrial environments
	EN 61000-6-3, Emission residential environments <sup>a</sup>
	EN 61000-6-4, Emission industrial environments
	EN 50121-4/IEC 62236-4, Railway and telecommunications apparatus
Marine <sup>a</sup>	DNV GL rules for classification - Ships and offshore units
EMI	FCC Part 15.105 class B
IECEX/ATEX <sup>b</sup>	IEC 60079-0 General requirements IEC 60079-15 Equipment protected by type of protection "n"
Environmental <sup>c</sup>	NEMA TS2
Safety	EN/IEC/UL 60950-1, IT equipment

<sup>a</sup>Valid for DDW-x42

<sup>b</sup>Valid for DDW-142-EX

<sup>c</sup>Valid for DDW-x42-12VDC and DDW-x42-12VDC-BP

Model	DDW-x42	DDW-x42-12VDC	DDW-142-EX	DDW-x42-12VDC-BP	DDW-x42-485
-------	---------	---------------	------------	------------------	-------------

MTBF hours					
MIL-HDBK-217-F	437,000	437,000	437,000	437,000	435,000

Interfaces					
Copper ports	2	2	2	2	2
SHDSL ports	2	2	2	2	2
RS-232 ports	1	1	1	1	
RS-485 ports					1
SHDSL bypass relay				1	
Console USB 2.0	1	1	1	1	1
I/O Digital input	1	1	1	1	1
I/O Digital output	1	1	1	1	1

Switch properties	
Number of VLAN	64
Priority queues	4

Software	
WeOS	<a href="https://www.westermo.com/solutions/weos">https://www.westermo.com/solutions/weos</a>
WeConfig	<a href="https://www.westermo.com/solutions/weconfig">https://www.westermo.com/solutions/weconfig</a>

Warranty	
Validity	5 years

Art.no.	Product	Functionality
3642-0300	DDW-142, Industrial Ethernet extender	Layer 2
3642-0400	DDW-142-12VDC, Industrial Ethernet extender	Layer 2
3642-0440	DDW-142-12VDC-BP, Industrial Ethernet extender with bypass relay	Layer 2
3642-0310	DDW-142-485, Industrial Ethernet extender	Layer 2
3642-5300	DDW-142-EX, Industrial Ethernet extender	Layer 2
3642-0320	DDW-242, Industrial Ethernet extender	Layer 3
3642-0420	DDW-242-12VDC, Industrial Ethernet extender	Layer 3
3642-0450	DDW-242-12VDC-BP, Industrial Ethernet extender with bypass relay	Layer 3
3642-0330	DDW-242-485, Industrial Ethernet extender	Layer 3

Accessories	
1211-2027	Diagnostic cable (console, accessories)
3125-0150	PS-60, power supply, DIN-mounted (accessories)
WeConfig	<a href="https://www.westermo.com/products/software/weconfig">https://www.westermo.com/products/software/weconfig</a>

## Specification WeOS 4

The WeOS operating system has been developed by Westermo for its current as well as future range of Ethernet hardware products. This layer 2 and layer 3 switching solution enables Westermo to create complex multimedia ring networks and routing solutions. WeOS not only provides solutions to many challenging industrial networking issues, but also helps to protect investments by ensuring the future availability of fully compatible solutions. WeOS is the core of our latest ranges of Ethernet hardware allowing complex multimedia ring networks and routing solutions to be created.

Westermo has many years of experience developing products for industrial applications. At the heart of all Westermo networking solutions is the need for ease of use. By standardising on a single operating system for all Westermo Ethernet products this helps to simplify the installation, operation and maintenance of individual devices and complete networks. Once a user is familiar with a Westermo product, that knowledge can be readily applied to all our other devices. A web screen simplifies the configuration of many functions, whilst a command line interface allows for fine tuning.

WeOS incorporates unique functions that allow Westermo solutions to provide integration paths for legacy equipment. WeOS also enables Westermo to deliver a range of unique network security solutions, utilising elements such as stateful inspection firewalls and the IEEE 802.1X standard. Remote secure access can be provided using encrypted VPN tunnels. The WeOS Management Guide, 6101-3201, explains how many of these functions can be set up.

WeOS Standard - Layer 2 protocols and functionality
<b>Resilience and High Availability</b> FRNTv0/v2 flexible ring topologies (multiring, subrings and ring coupling), Multilink dual homing, IEC 62439-2 Media Redundancy Protocol (MRP) <sup>a</sup> , IEEE 802.1AX/802.3ad Link Aggregation (LACP and static), IEEE 802.1D Spanning Tree Protocol (STP) and IEEE 802.1w Rapid Spanning Tree Protocol (RSTP)
<b>Layer 2 Switching</b> IEEE 802.1Q Static VLAN and VLAN Tagging, VLAN Q-in-Q tunnelling, VLAN transparency, IEEE 802.3x Flow Control, IGMPv2/v3 Snooping, AVT Dynamic VLAN (Adaptive VLAN Trunking), Management VLAN (Management Interface concept), Static Multicast MAC filters, IEEE 802.1AB Link Layer Discovery Protocol (LLDP)
<b>Layer 2 QoS</b> IEEE 802.1p Class of Service, Ingress/inbound rate limiting, Egress/outbound traffic shaping
<b>Layer 2 Security</b> IEEE 802.1X Port Access Control, MAC Authentication, IP/MAC address conflict detection, Port Auto-Disable
<b>Serial Port Technologies</b> Serial over IP (Serial Extender and Virtual Serial Port), Modem replacement, Modbus Gateway, Microlok II Gateway
<b>Manageability</b> WeConfig, Web interface (HTTP and HTTPS), Command Line Interface (CLI) via console port, (SSHv2 and Telnet), Local and central user authentication (RADIUS and TACACS+), SNMPv1/v2c/v3, Secure Copy (SCP), USB configuration and backup, BOOTP client, flexible alarm/event handling system, Syslog (log files on RAM/USB and remote syslog server), Digital I/O, Persistent Port Monitoring, NTPv4 Client/Server, DHCP client (including options 60 and 61), DHCP server (including options 1, 3, 6, 7, 12, 15, 42, 61, 66, 67, 82, 121 and 249), DHCP relay agent (including options 54 and 82), DDNS
<b>SNMP MIB Support</b> RFC1213 MIB-2, RFC 2819 RMON MIB, RFC 2863 Interface MIB, RFC 3411 SNMP Framework MIB, RFC 3433 Entity Sensor MIB, RFC 3635 Ethernet-like MIB, RFC 4133 Entity MIB, RFC4188 Bridge MIB, RFC4318 RSTP MIB, RFC4363 Q-BRIDGE MIB, RFC4836 MAU MIB, RFC4319 HDLSL2/SHDSL MIB, IEEE 802.1AB LLDP MIB, IEEE 802.1AX LAG MIB, IEC 62439-2, MRP <sup>a</sup> , UCD SNMP MIB, WESTERMO-WEOS MIB, WESTERMO-FRNT MIB, WESTERMO-INTERFACE MIB

<sup>a</sup>Available as add-on-function. Please see your local Westermo sales contact to purchase a license for your product.

WeOS Extended - Layer 3 protocols and functionality <sup>a</sup>
<b>IP Routing, Cyber Security and VPN</b> Static IP routing, Floating Static Routes, Dynamic IP routing (OSPFv2, RIPv1/v2), VRRPv2/v3, Static Multicast Routing, Stateful Inspection Firewall, NAT, 1-1 NAT, Proxy ARP for 1-1 NAT, Port Forwarding, DSCP/TOS modification, IPsec VPN (IKEv1 certificates and PSK, ESP, VPN failover), SSL VPN (Client and Server, Local and central authentication with RADIUS, address pool and address per CN, TLS authentication, WeConnect), GRE, Multinetting
<b>Serial Port Technologies</b> PPP dial in/dial out
<b>SNMP MIB Support</b> RFC 2787 VRRPv2 MIB, RFC 6527 VRRPv3 MIB

<sup>a</sup>Products with software level WeOS Extended include all functionality listed for WeOS Standard